

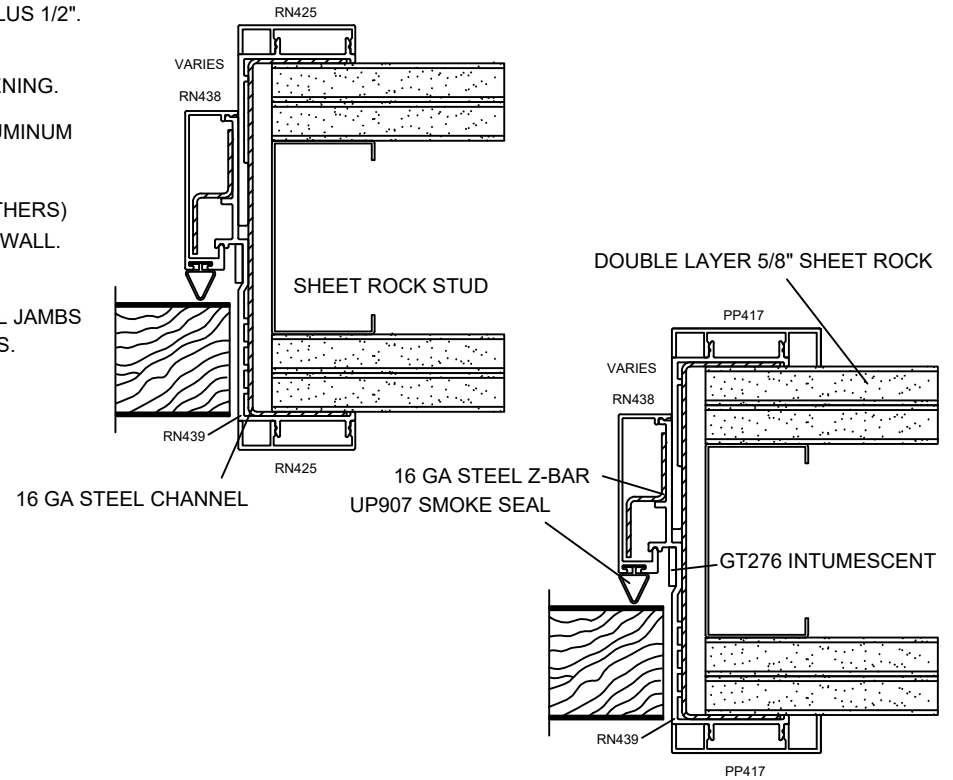

SOLUTIONS I 45/60/90 Minute Positive Pressure Door Frame Installation Instructions

COMES PRE-SET FROM FACTORY TO DESIRED WALL THICKNESS

1. MAKE SURE ROUGH OPENING IS DOOR OPENING WIDTH PLUS 1" AND DOOR OPENING HEIGHT PLUS 1/2".
MAXIMUM OPENING SIZE 4x9 SINGLE AND 8x9 DOUBLE.
2. INSTALL HEADER WHILE LEAVING DOOR STOP PRE-ATTACHED TO HEADER AND CENTER IN OPENING.
3. CAM EACH VERTICAL JAMB INTO THE SLOTS AT THE END OF THE HEADER IN BETWEEN THE ALUMINUM AND THE STEEL CORNER CLIP THAT IS WELDED TO THE HEADER. (SEE DIAGRAM).
4. LEVEL THE HEADER AND SCREW THE HEADER TO THE WALL WITH SHEET ROCK SCREWS (BY OTHERS) LONG ENOUGH TO SCREW THROUGH ALL LAYERS OF SHEET ROCK AND INTO METAL STUD IN THE WALL. MAKE SURE TO PLACE A SCREW IN ALL PREDRILLED HOLE LOCATIONS.
5. ATTACH 90 DEGREE CORNER CLIPS AT TOP CORNERS AND SCREW TO THE HEADER & VERTICAL JAMBS HOLDING THE HOLDING THE HEADER AND JAMBS TIGHT TO KEEP MINIMAL GAP AT ALL SIGHT LINES.

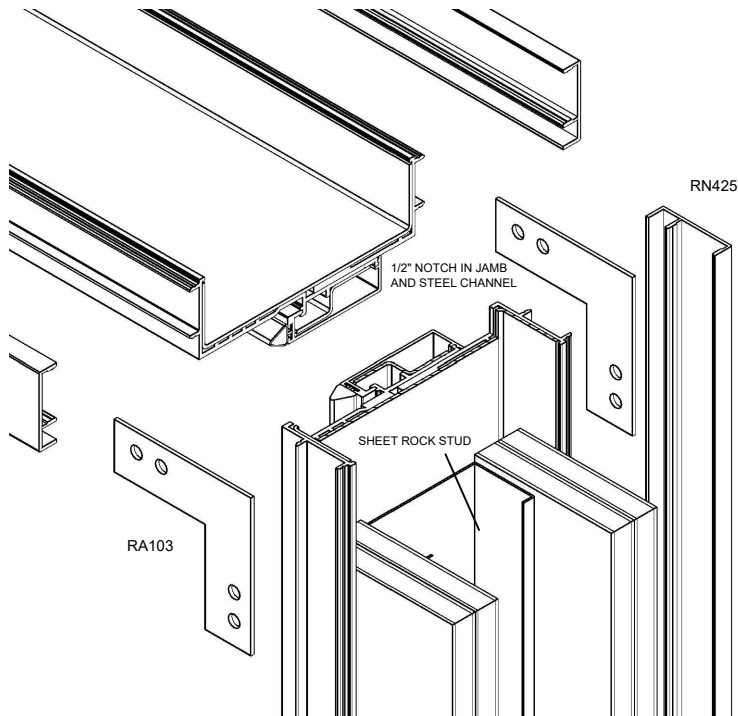

6. PLUM AND LEVEL VERTICAL JAMBS AND SCREW TO WALL WITH SHEET ROCK SCREWS LONG ENOUGH TO SCREW THROUGH ALL LAYERS OF SHEET ROCK AND INTO METAL STUD IN THE WALL. MAKE SURE TO PLACE A SCREW IN ALL PREDRILLED HOLE LOCATIONS.
7. ATTACH HEADER DOOR STOP BY PLACING ONE END INTO CORNER AND LIFTING OTHER END UP AND INTO POSITION AT THE HEADER. SLIDE THE DOOR STOP TOWARDS DOOR SIDE AND LOCK DOOR STOP INTO SLOT. THEN SNAP OTHER SIDE DOWN TO HEADER WITH MILD PRESSURE. DO NOT HIT DOOR STOP WITH RUBBER MALLOT. USE BLOCK OF WOOD BETWEEN MALLOT AND DOOR STOP TO KEEP FROM DENTING DOOR STOP.
8. INSTALL VERTICAL JAMB STOPS.
9. INSTALL FRAME TRIM VERTICALS. TRIM IS HANDED WITH CLEARANCE CUT OUT AT TOP OF TRIM TO CLEAR CORNER CLIPS. MAKE SURE TOP OF VERTICAL TRIM IS EVEN WITH TOP OF HEADER TRIM. INSTALL HEADER TRIM IN BETWEEN VERTICAL TRIM.
10. IF USING CYLINDRICAL LOCK. INSTALL RACO SUPPLIED EXTENDED LIP STRIKE PLATE. (ALL OTHER TYPES BY OTHERS).

NOTE:
SLIDE JAMB UP SO THAT THE WELDED ANGLE CLIP IS LOCATED BETWEEN STEEL JAMB CHANNEL AND SHEET ROCK ON JAMB

Revised 3/5/2020

NOT TO SCALE